

Data sheet

**M12 Industrial Ethernet cable, X-coded, 1.0 m,
M12 plug straight - RJ45 plug straight, drag chain, PUR**

P/N
142M6X18010
EAN 4250184198277
2025/05/19
Version: L

Technical Data

General Data	
Fields of application	Industrial Ethernet harsh environment
Design	Ethernet-Connection line
Shielding	shielded
Transmission technology	Copper
Cable Type	SF/UTP
Number of twisting elements	4
Twisting element	Pair
Wiring	T568B
Color coding fiber/ wire(s)	white, orange, white, green, white, brown, white, blue
Color	green
Dimensions	
Dimension - Interface 1 (L x W x H)	50.5 mm x 15 mm x 15 mm
Dimension - Interface 1 (L x W x H)	1.988 in. x 0.591 in. x 0.591 in.
Dimension - Interface 2 (L x W x H)	48.8 mm x 13.8 mm x 13.8 mm
Dimension - Interface 2 (L x W x H)	1.921 in. x 0.543 in. x 0.543 in.
Cable length (m)	1 m
Cable length (ft)	3.28 ft

Transmission characteristics	
Category (ISO)	6 _A

Connections/interfaces	
Connector technology interface 1	M12-plug
Connector technology interface 2	RJ45 plug
Coding interface 1	X-coded
Coding interface 2	T568B
Number of positions/contacts interface 1	8
Number of positions/contacts interface 2	8P/8C

Data sheet

**M12 Industrial Ethernet cable, X-coded, 1.0 m,
M12 plug straight - RJ45 plug straight, drag chain, PUR**

P/N
142M6X18010
EAN 4250184198277
2025/05/19
Version: L

Technical Data

Connections/interfaces

Termination data, stranded wire (min. - max.)

Conductor cross section, stranded wire	AWG 26/19
Conductor diameter, stranded wire (bare copper)	0.55 mm
Conductor diameter, stranded wire (bare copper)	0.022 in.
Core diameter (min. - max.)	
Core diameter (conductor with insulation)	0.98 mm
Core diameter (conductor with insulation)	0.039 in.
Cable sheath diameter (min. - max.)	
Cable sheath diameter	7.80
Cable sheath diameter	0.307

Electrical characteristics

Current carrying capacity	0.5 A at 40 °C
Insulation resistance	min. 100 MOhm
Transfer impedance 10 MHz	max. 30 mOhm/m
Capacitance at 800 Hz	52 nF/km
Delay skew	30 ns/100 m

Mechanical data

Tensile force	100 N
Life - Number of mating cycles	min. 100
Bending radius without load	31.2 mm
Bending radius without load	1.228 in.
Bending radius with load	58.5 mm
Bending radius with load	2.303 in.
Maximum operating bending radius	58.5 mm
Maximum operating bending radius	2.303 in.
Number of alternating bending cycles (mechanical resistance) at:	4 million bending cycles
Alternating bending radius	58.5 mm
velocity	3 m/s
acceleration	3 m/s ²
Shielding braid coverage	85 %

**M12 Industrial Ethernet cable, X-coded, 1.0 m,
M12 plug straight - RJ45 plug straight, drag chain, PUR**

P/N
142M6X18010
EAN 4250184198277
2025/05/19
Version: L

Technical Data

Materials and material properties

Material - Conductor	Cu (copper)
Material - Conductor Insulation	polypropylene
Material - Cable jacket	PUR
Material - Inner cable jacket	FRNC, with an aluminized film
Material - Contact interface 1	CuZnPb (brass)
Material - Contact interface 2	CuSn
Material - Contact finish interface 1	Au (gold)
Material - Contact finish interface 2	Au (gold)
Material - Contact carriers interface 1	Plastics
Material - Contact carriers interface 2	Plastics
Material - Main shield	Cu (copper) braid
Material - Main shield finish	Sn
Flame retardancy	according to IEC 60332-1-2
Halogen free	yes
Oil resistance	yes
UV-resistance	yes
drag chain suitable	yes
RoHS	compliant

Environmental conditions

Temperature (min. - max.)	
Temperature - Operating °C	-30 °C - 70 °C
Temperature - Operating °F	-22 °F - 158 °F
Particulate ingress interface 1	IP6X when plugged in
Liquid ingress/immersion interface 1	IPX5, IPX7 when plugged in
Particulate ingress interface 2	IP2X when plugged in
Liquid ingress/immersion interface 2	IPX0 when plugged in
Pollution degree interface 1	2
Pollution degree interface 2	1

Data sheet

Page 5/7

**M12 Industrial Ethernet cable, X-coded, 1.0 m,
M12 plug straight - RJ45 plug straight, drag chain, PUR**

P/N

142M6X18010

EAN 4250184198277

2025/05/19

Version: L

Technical Data

Approvals

UL listed (file no.) Approval pending

Standards/Regulations

Generic cabling systems

General requirements ISO/IEC 11801 | ANSI/TIA-568

Connectors for electronic equipment

circular connector DIN EN 61076-2-109

Multi-element metallic cables used in analogue and digital communication and control DIN EN 50288-5-2

Test for vertical flame propagation for a single insulated wire or cable IEC 60332-1-2

Determination of the halogen acid gas content IEC 60754-1

Classifications

ETIM 7.0 EC002599

ETIM 8.0 EC002599

ETIM 9.0 EC002599

Packing details

Type of packaging 1 pc(s) / plastic bag

Application note

This product is a standard product of METZ CONNECT. METZ CONNECT is not aware of the specific intended use of the goods by the Customer or any customers of the Customer. The Customer guarantees that it has fully and sufficiently tested the use of the goods and any product modifications, product changes or product enhancements with regard to the specific intended use in accordance with the state of the art or in any other way. At METZ CONNECT's request, the Customer shall submit and make available meaningful evidence (e.g. test and laboratory protocols, certifications, etc.).

**M12 Industrial Ethernet cable, X-coded, 1.0 m,
M12 plug straight - RJ45 plug straight, drag chain, PUR**

P/N
142M6X18010
EAN 4250184198277
2025/05/19
Version: L

Illustrations

Dimensional drawing

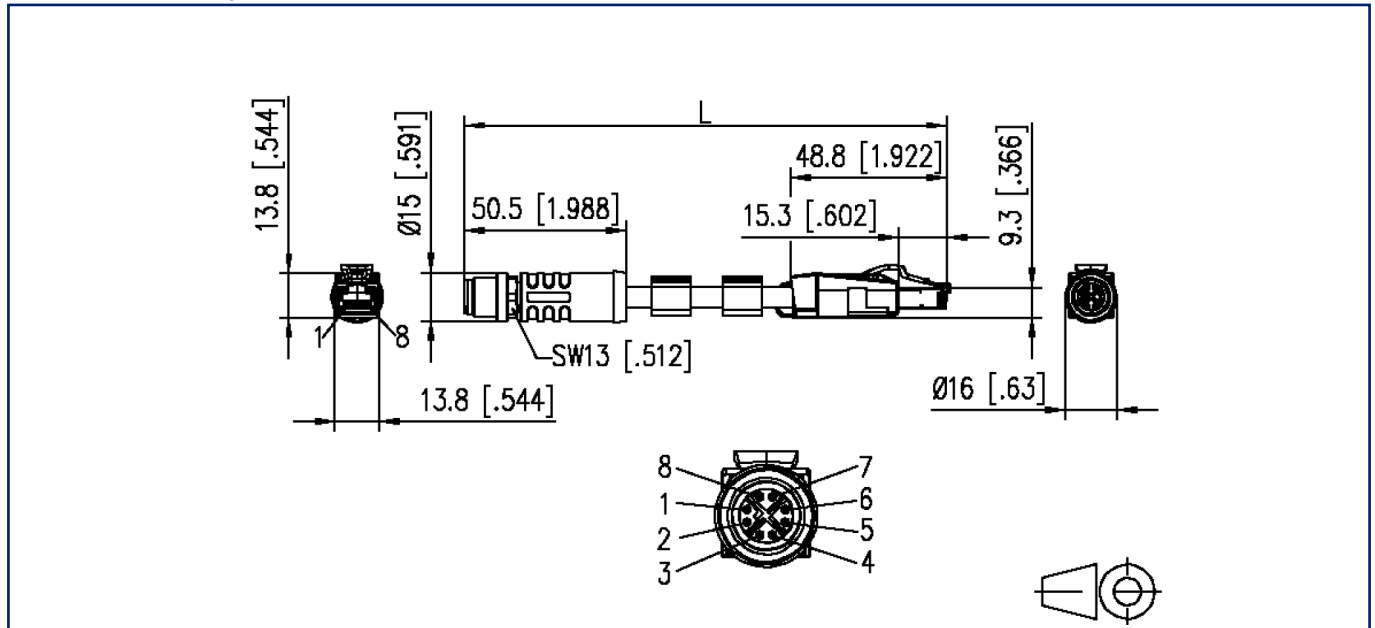

Wiring diagram

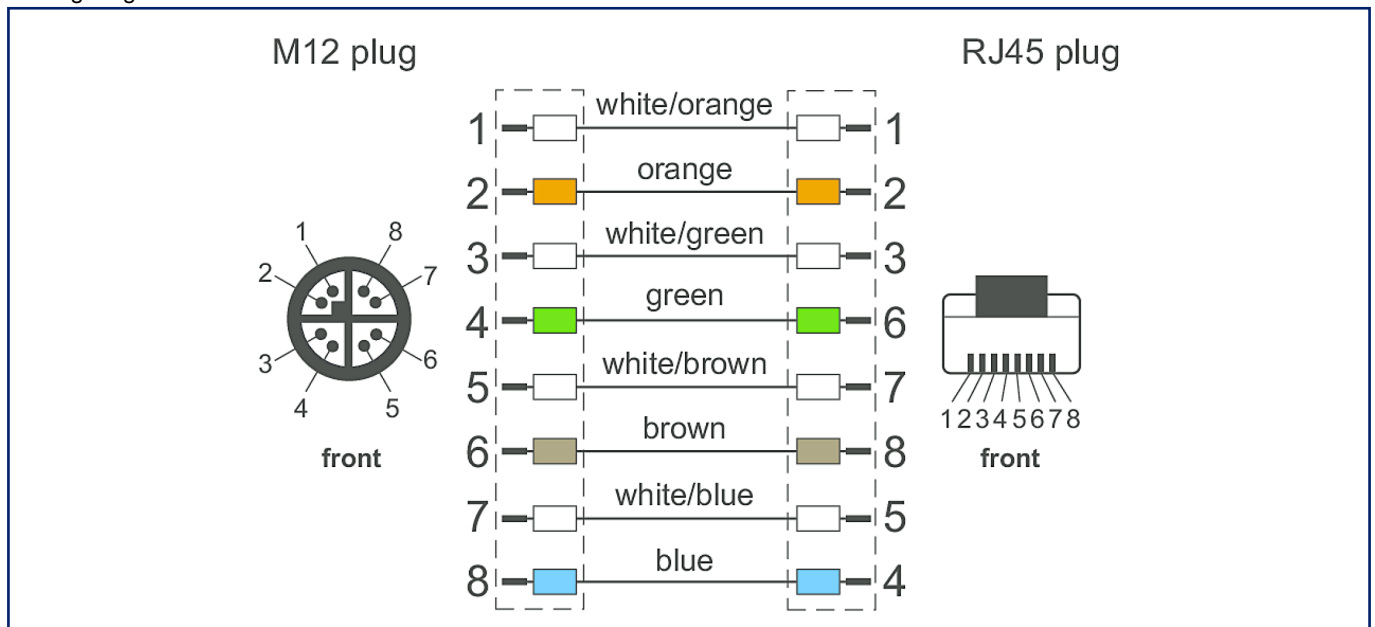

© 2025 METZ CONNECT - Technische Änderungen vorbehalten! Subject to modifications! Sous réserve de modifications techniques!

Data sheet

Page 7/7

**M12 Industrial Ethernet cable, X-coded, 1.0 m,
M12 plug straight - RJ45 plug straight, drag chain, PUR**

P/N

142M6X18010

EAN 4250184198277

2025/05/19

Version: L

Illustrations

Principle diagram

