

KAPri plus M12 extension kits – The optimum extension kits for error-free network cabling across all levels



Cabling and installation requirements

Never before has there been such a high demand for data transmission volumes. IT technologies are used in a multitude of applications in buildings and industry. The requirements lead to consistent communication over all company divisions without interface and communication losses, resulting in service-neutral cabling between all levels. Anticipatory and intelligent cabling systems that connect several segments must therefore be tuned perfectly to each other – in order to guarantee a sustainable, continuous and loss-free form of communication.

With increasing demand for Industrial Ethernet, network cabling systems are no longer used only in offices, homes and data centers, but increasingly also in industry and distributed building services. There both RJ45 connectors and M12 round connectors are in use.

The RJ45 plug connection has become established as the connection system for the Internet age in particular in building and hall cabling systems. However, due to the extension of data networks also to rough, industrial production environments, the requirements of plug connections have changed decisively.

M12 connections have been part of the standard of industrial bus systems for a long time. They are optimally adjusted to the environmental conditions prevalent in production halls. Whereas RJ45 is becoming more and more important in switch cabinets and distributors, M12 connectors must meet new transmission performance requirements, due to the increasing use of Ethernet in industry.

An important feature of sustainable, structured building cabling systems are consistent, internationally standardized and high-performance network components that meet the transmission technology requirements and remain easy to use.

Despite the attempt to use components that are easy to operate, it can happen that the installed network cabling systems are faulty or have not been connected correctly. This results in installation faults such as split pair, loose contacts, short-circuits, wire mix-ups, line mix-ups or external voltages. The installation faults may occur during new installations, retrofittings and repair work.

If these installation faults are not detected until commissioning is carried out, this often results in very expensive testing of the network cabling system, requiring another trip by the installers in order to eliminate the faults.

To counteract these cost-intensive tests and repairs, suitable installation testing devices are used directly after installation, in order to analyze any faults that may have occurred.

Previously, the detection of installation faults was only possible by using suitable installation testers for RJ45 connections. A suitable device for this is the KAPri plus testing device from METZ CONNECT, while until now the testing of M12 connections for the most frequent installation faults has not been possible. For this area of application, suitable M12 X- or D-coded extension kits for the existing KAPri plus testing device and similar and compatible installation testers are now available on the market, allowing the previously mentioned installation faults to be tested in installation lines with M12 jacks or plugs.



KAPRi plus cable and installation tester

Cable and installation tester and extension kits for a consistently secured network with RJ45 and M12 connectors

The KAPRi plus cable and installation tester

- > is a handy testing device for detecting the most important installation faults
- > for testing installed RJ45 and M12 solutions (combined with the M12 extension kits)
- > for Ethernet communication on almost any level, from the field level, control level and structured
- > cabling in company networks to computer centers and home cabling
- > featuring easy operation and interpretation of the test results

The cable and installation tester KAPRi plus easily, quickly and reliably detects the most frequent installation faults such as short-circuit, wire interruption, wire and cable mix-up in data cabling systems. In addition to its basic fault detection functions, the KAPRi plus has further useful performance characteristics such as line identification through detection of up to nine test box numbers (optionally available as test box sets 2 to 5 and 6 to 9), display of external voltage and its polarity, adjustability of pin assignment, automatic switch-off, loose contact test and many more.

For use in all areas of structured building cabling with RJ45 connectors.

Application in new installations, retrofitting and repairs in particular of field-assembled connectors and installation lines. A direct test of the installation line following installation allows cost-intensive failures, troubleshooting during commissioning and rework to be shortened or to be avoided in advance.



Performance characteristics of the KAPRi plus cable and installation tester

Detection of the most important installation faults

- > Split pair
- > Loose contact
- > Defect wire
- > Short-circuit
- > Wire mix-up
- > Cable mix-up
- > External voltage

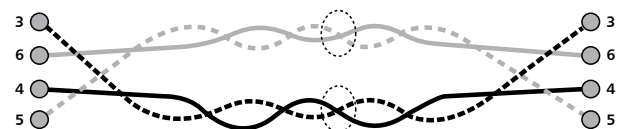

Example of "split pairs": The white wires of pairs 3/6 and 4/5 were interchanged. It can be seen that the contacts are contacted 1:1, but the wires on contacts 3 and 5 are interchanged on both sides.

Performance characteristics

- > Automatic test procedure
- > Quick and clear display of the error type by a 7-segment display
- > Easy operation and interpretation of the test results
- > Separate key to display error list for multiple errors
- > Display of external voltages at the tested connection with display of the polarity
- > Line identification of up to nine lines through detection of up to nine test box numbers
- > 9-wire connection line to test up to 8-wire data connection lines with shield
- > Fault display for each individual wire by nine red LEDs
- > Detection of mix-ups inside and outside of cable pairs
- > Test function to detect loose contacts
- > Nine switches for individual adjustment of the pin assignment
- > Detection and display of a wrongly set pin assignment in the device
- > Length of the line to be tested up to approx. 1000 m
- > Low current consumption for long battery life
- > Automatic switch-off after 30 seconds
- > Low voltage display for battery

Application example KAPri plus

Connection for testing RJ45 installation lines

To test an installation line with RJ45 jacks at both ends, for example from the patch panel to the wall outlet, for installation faults using the KAPri plus, the yellow RJ45 patch cord (delivered with the KAPri plus basic unit) is connected to the KAPri plus basic unit and the other end of the patch cord is plugged into the RJ45 jack at one end of the installation line

to be tested. At the other end, the test box is plugged into the RJ45 jack of the installation line to be tested. If a line identification is to be carried out simultaneously, a KAPri plus test box (a max. of 9 test boxes are available as accessories) is plugged into each of the connections to be tested.

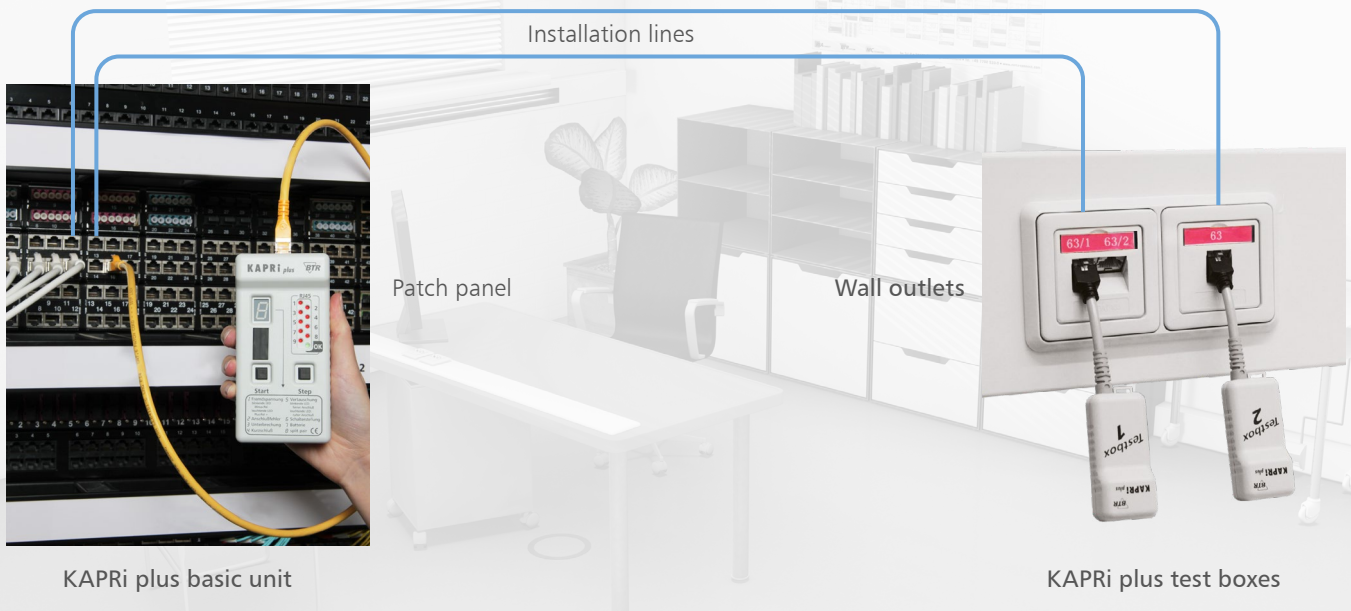

Connection for testing RJ45 patch cords

If you want to test a patch cord or an installed field-assembled line with RJ45 connectors at both ends for installation faults, just plug one end of the patch cord or of the installation line into the

RJ45 jack of the KAPri plus basic unit and the other end of the patch cord or of the installation line into the RJ45 jack of the KAPri plus test box.



KAPri PLUS BASIC UNIT INCLUDING TEST BOX 1 AND PATCH CORD



P/N 130670-E

KAPri PLUS TEST BOX 2-5



P/N 130671-E

KAPri PLUS TEST BOX 6-9



P/N 130672-E

KAPri PLUS TEST BOX 1



P/N 130673-01-E

KAPri plus M12 extension kits, X-coded and D-coded

The KAPri plus cable and installation tester was previously available as basic unit with accessories. Optional accessories were test box 1 and the KAPri plus test box extension kits, with test boxes 2 to 5 or 6 to 9. The previous components are now supplemented by an X-coded M12 extension kit and a D-coded M12 extension kit.

This allows the M12 jacks to be connected to the testing device and the test box by means of the M12/RJ45 connection line and the connectors on the installation lines to be connected by means of the adapter M12 on RJ45. This means



that no additional testing device is necessary for testing an M12 cabling system.

Application in all areas of structured building cabling systems, especially industrial cabling systems (Industrial Ethernet) using M12 components, communication cable systems, automation/control systems, industrial automation, building automation or traffic automation.

Connection for testing M12 installation lines

To test an installed M12 line with, for example, two M12 jacks for installation faults, using the KAPri plus, one M12 plug of each of the two M12/RJ45 connection lines from the extension kit is plugged into the M12 jacks of the installation line. The RJ45

jack of one M12/RJ45 connection line is plugged into the RJ45 jack of the KAPri plus basic unit and the RJ45 plug of the other M12/RJ45 connection line is plugged into the RJ45 jack of the KAPri plus test box.

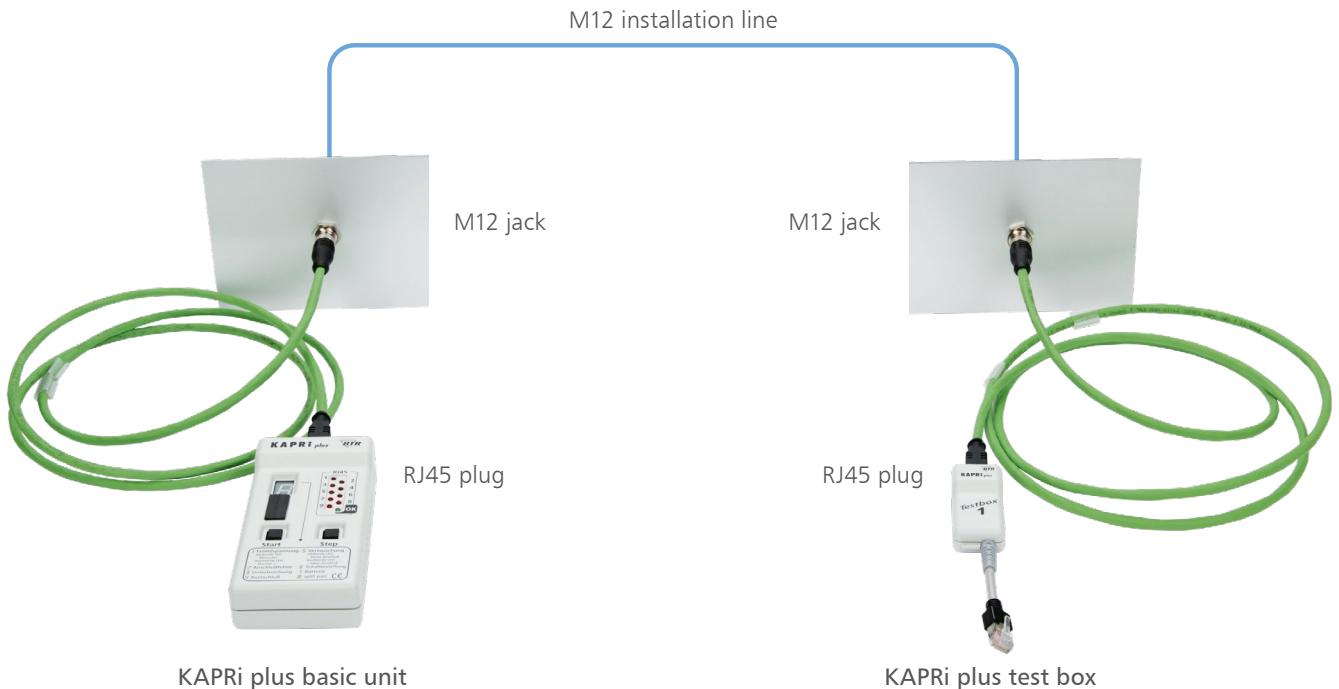



Connection for testing M12 X-coded connection lines

If you want to use the KAPri plus to check an M12 connection line with two M12 plugs, just plug one M12 plug each of the installation line to be tested into the M12 jack of the M12X/RJ45 adapters. The KAPri plus basic unit and one of the M12X/RJ45

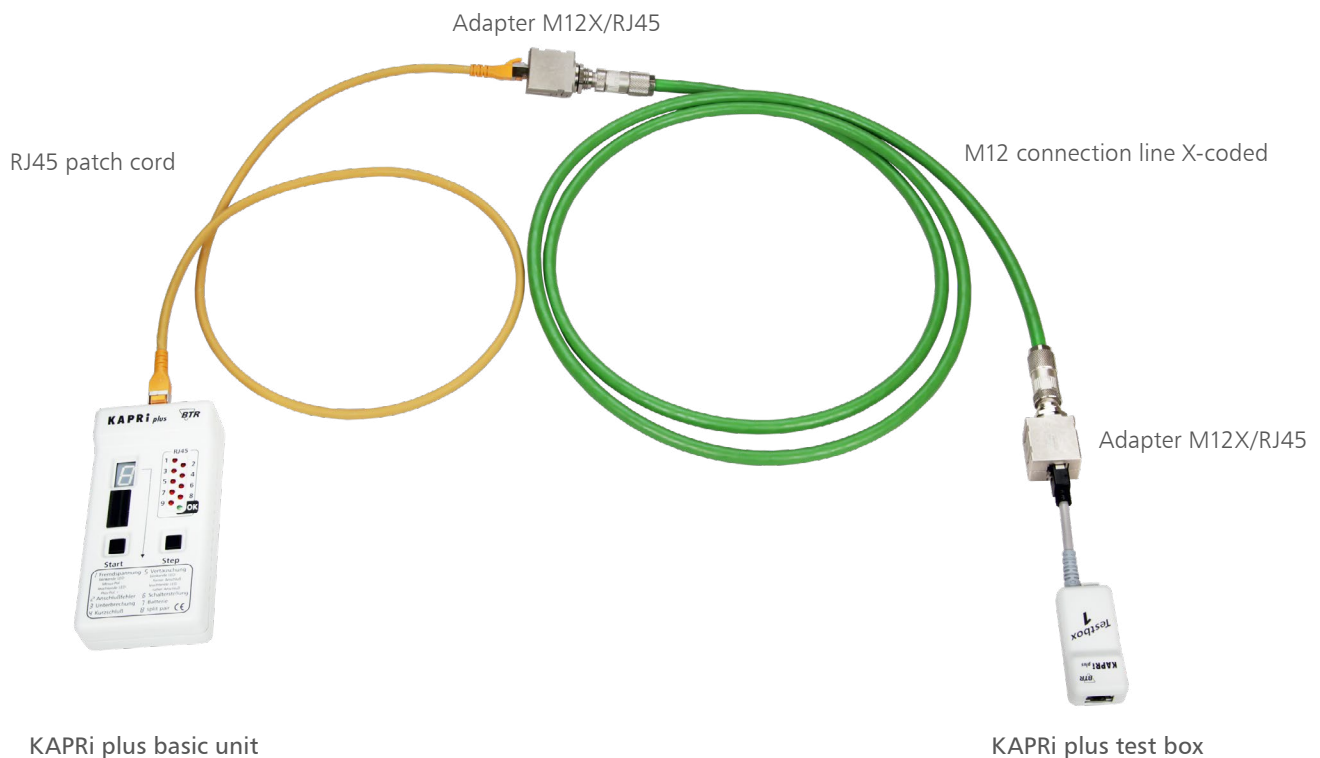
adapters are connected via the RJ45 patch cord. The other M12X/RJ45 adapter and the KAPri plus test box are connected via the RJ45 connection line of the test box.



	PRODUCT NAME	DELIVERY CONTENTS	P/N
	Scope of delivery KAPri plus X-coded M12 extension kit	2x adapters M12X/RJ45 straight 2x connection cables M12/RJ45 8-pole X-coded 2.0 m 1x KAPri plus plastic case with cutouts 1x operating instructions	130674-E
	Scope of delivery KAPri plus D-coded M12 extension kit	2x adapters M12D/RJ45 straight 2x connection cables M12/RJ45 4-pole D-coded 2.0 m 1x operating instructions	130675-E

Plastic case with cutouts for the complete KAPri plus set

- › The solid KAPri plus plastic case made of polypropylene has room for all previous components and the extension kits
- › Inside the case, the components are stored protected from dust and dirt
- › The components are clearly arranged and thus within easy reach
- › The complete set is always present
- › The components fit tightly in their respective cutouts of the hard foam insert of the lower part and can be easily checked for completeness
- › The gray dividing plate and the eggshell foam insert in the upper part assure secure transport of patch cord and connection lines
- › The KAPri plus components can be used to check consistent, application-neutral networks in homes, offices or data centers and industry for installation faults
- › RJ45 and M12 installation lines can be tested

KAPRI PLUS PLASTIC CASE COMPLETELY EQUIPPED

P/N 130676-01-E

- › 1x KAPri plus basic unit
- › 1x KAPri plus test box 1
- › 1x KAPri plus test box set 1 including test boxes no. 2, 3, 4, 5
- › 1x KAPri plus test box set 2 including test boxes no. 6, 7, 8, 9
- › 2x adapters M12X/RJ45 straight
- › 2x adapters M12D/RJ45 straight
- › 2x connection cables M12/RJ45 8-pole X-coded 2.0 m
- › 2x connection cables M12/RJ45 4-pole D-coded 2.0 m
- › 1x patch cord RJ45 1.0 m
- › 1x KAPri plus plastic case with cutouts

KAPRI PLUS PLASTIC CASE UNEQUIPPED

P/N 130676-E

- › 1x KAPri plus plastic case with cutouts



METZ CONNECT GmbH is member of the following organizations and associations.



METZ CONNECT GmbH

Im Tal 2
78176 Blumberg
Germany

Phone +49 7702 533-0
Fax +49 7702 533-189

info@metz-connect.com
www.metz-connect.com



METZ CONNECT USA Inc.

200 Tornillo Way
Tinton Falls, NJ 07712
USA

Phone +1-732-389-1300
Fax +1-732-389-9066

METZ CONNECT France SAS

28, Rue Schweighaeuser
67000 Strasbourg
France

Phone +33 3886 170 73
Fax +33 3886 194 73

METZ CONNECT Zhongshan Ltd.

Ping Chang Road
Ping Pu Industrial Park
Sanxiang Town
Zhongshan City, 528463
Guangdong Province
China

Phone +86 760 86365 055
Fax +86 760 86365 050

METZ CONNECT Asia Pacific Ltd.

Suite 1803, 18/F
Chinachem Hollywood Centre,
1 Hollywood Road, Central
Hong Kong

Phone +852 26 027 300
Fax +852 27 257 522

