

# Data sheet

**M12 Industrial Ethernet cable, X-coded, 2.0 m,  
M12 plug straight - free line end, torsion, PUR**

Page 1/7

P/N  
**142M7X10020**  
EAN 4250184199281  
2025/05/19  
Version: L

## Illustrations

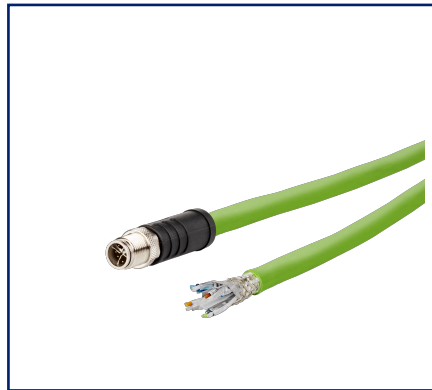

Dimensional drawing

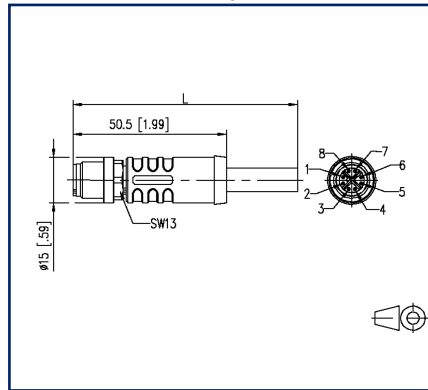

Wiring diagram

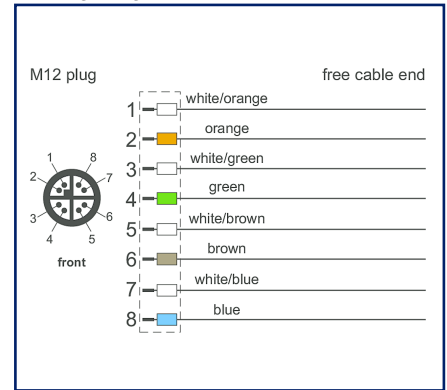

See enlarged drawings at the end of document

## Product specification

PROFINET 4x2xAWG24/7 Type C torsion-resistant high-speed data cable of transmission category Cat 7. The cable is halogen-free, flame-retardant, oil-resistant and resistant to abrasion due to the PUR outer jacket. It is ideally suited for use in industrial environments. High-quality shielding ensures high transmission reliability of the data in electromagnetically stressed areas. Suitable for use in dry and humid rooms. Special properties: c(UL)us type CMX according to UL 444, UL AWM styles 11117 and 21576 (1000 V, 80 °C) according to UL 758, flame retardant, recyclable, LABS-free, RoHs compliant, ozone resistant, UV resistant, torsion resistant, halogen free, oil resistant.

- Standard variants: 1.0 m, 2.0 m, 5.0 m, 10.0 m.
- Other cable lengths on request.

Data sheet

**M12 Industrial Ethernet cable, X-coded, 2.0 m,  
M12 plug straight - free line end, torsion, PUR**

P/N  
142M7X10020  
EAN 4250184199281  
2025/05/19  
Version: L

**Technical Data**

**General Data**

Fields of application	Industrial Ethernet harsh environment
Design	Ethernet-Connection cable
Shielding	shielded
Transmission technology	Copper
Cable Type	S/FTP
Number of twisting elements	4
Twisting element	Pair
Wiring	1 - 1
Color coding fiber/ wire(s)	white/orange, orange, white/green, green, white/brown, brown, white/blue, blue
Color	green
Dimensions	
Dimension - Interface 1 (L x W x H)	50.5 mm x 15 mm x 15 mm
Dimension - Interface 1 (L x W x H)	1.988 in. x 0.591 in. x 0.591 in.
Cable length (m)	2 m
Cable length (ft)	6.56 ft

**Transmission characteristics**

Category (ISO)	6 <sub>A</sub>
Transmission rate up to 10 GBit	IEEE 802.3an

**Connections/interfaces**

Connector technology interface 1	M12-plug
Connector technology interface 2	free line end
Coding interface 1	X-coded
Number of positions/contacts interface 1	8
Termination data, stranded wire (min. - max.)	
Conductor cross section, stranded wire	AWG 24/7
Conductor diameter, stranded wire (bare copper)	0.2 mm
Conductor diameter, stranded wire (bare copper)	0.008 in.

Data sheet

**M12 Industrial Ethernet cable, X-coded, 2.0 m,  
M12 plug straight - free line end, torsion, PUR**

P/N  
142M7X10020  
EAN 4250184199281  
2025/05/19  
Version: L

**Technical Data**

**Connections/interfaces**

Cable sheath diameter (min. - max.)

Cable sheath diameter	9.4 mm
Cable sheath diameter	0.37 in.

**Electrical characteristics**

Current carrying capacity	0.5 A at 40 °C
Rated voltage	60 V DC
Insulation resistance	min. 100 MOhm

**Mechanical data**

Life - Number of mating cycles	min. 100
Torsion	at least 5.000.000 cycles
Maximum operating bending radius	75 mm
Maximum operating bending radius	2.953 in.
Maximum installation load	141 mm
Maximum installation load	5.551 in.
Shielding braid coverage	85 %

**Materials and material properties**

Material - Conductor	Cu (copper)
Material - Conductor Insulation	foamed Polyolefin
Material - Cable jacket	PUR
Material - Body interface 1	Plastics
Material - Contact interface 1	CuZnPb (brass)
Material - Contact finish interface 1	Au (gold)
Material - Contact carriers interface 1	Plastics
Material - Union nut interface 1	CuZnPb (brass)
Material - Union nut finish interface 1	Ni (nickel)
Material - Pair shield	plastic film
Material - Pair shield finish	Al (Aluminium)
Material - Main shield	Cu (copper) braid
Material - Main shield finish	Sn
Flame retardancy	according to IEC 60332-1-2
Halogen free	yes

Data sheet

**M12 Industrial Ethernet cable, X-coded, 2.0 m,  
M12 plug straight - free line end, torsion, PUR**

P/N  
142M7X10020  
EAN 4250184199281  
2025/05/19  
Version: L

**Technical Data**

**Materials and material properties**

Oil resistance	yes
torsional	yes
RoHS	compliant

**Environmental conditions**

Temperature (min. - max.)	
Temperature - Operating °C	-30 °C - 90 °C
Temperature - Operating °F	-22 °F - 194 °F
Particulate ingress interface 1	IP6X when plugged in
Liquid ingress/immersion interface 1	IPX5, IPX7 when plugged in
Pollution degree interface 1	2

**Approvals**

UL listed (file no.)		DUXR.E178484
----------------------	--	--------------

**Standards/Regulations**

Generic cabling systems	
General requirements	ISO/IEC 11801-1   DIN EN 50173-1
Connectors for electronic equipment	
circular connector	DIN EN 61076-2-109
Multi-element metallic cables used in analogue and digital communication and control	DIN EN 50288-5-2
Test for vertical flame propagation for a single insulated wire or cable	IEC 60332-1-2
Determination of the halogen acid gas content	IEC 60754-1

**Classifications**

ETIM 7.0	EC002599
ETIM 8.0	EC002599
ETIM 9.0	EC002599

Data sheet

Page 5/7

**M12 Industrial Ethernet cable, X-coded, 2.0 m,  
M12 plug straight - free line end, torsion, PUR**

P/N

142M7X10020

EAN 4250184199281

2025/05/19

Version: L

**Technical Data****Packing details**

Type of packaging 1 pc(s) / plastic bag

**Application note**

This product is a standard product of METZ CONNECT. METZ CONNECT is not aware of the specific intended use of the goods by the Customer or any customers of the Customer. The Customer guarantees that it has fully and sufficiently tested the use of the goods and any product modifications, product changes or product enhancements with regard to the specific intended use in accordance with the state of the art or in any other way. At METZ CONNECT's request, the Customer shall submit and make available meaningful evidence (e.g. test and laboratory protocols, certifications, etc.).



Data sheet

Page 6/7

**M12 Industrial Ethernet cable, X-coded, 2.0 m,  
M12 plug straight - free line end, torsion, PUR**

P/N  
142M7X10020

EAN 4250184199281

2025/05/19

Version: L

## Illustrations

Dimensional drawing

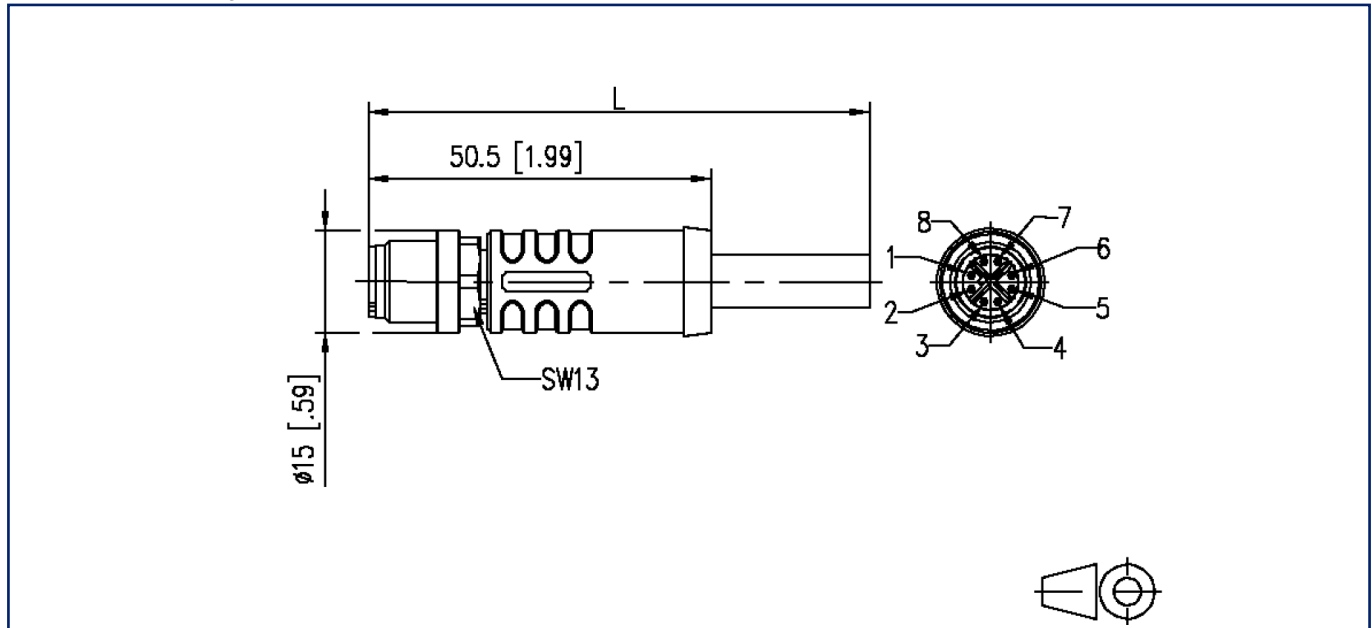

Wiring diagram

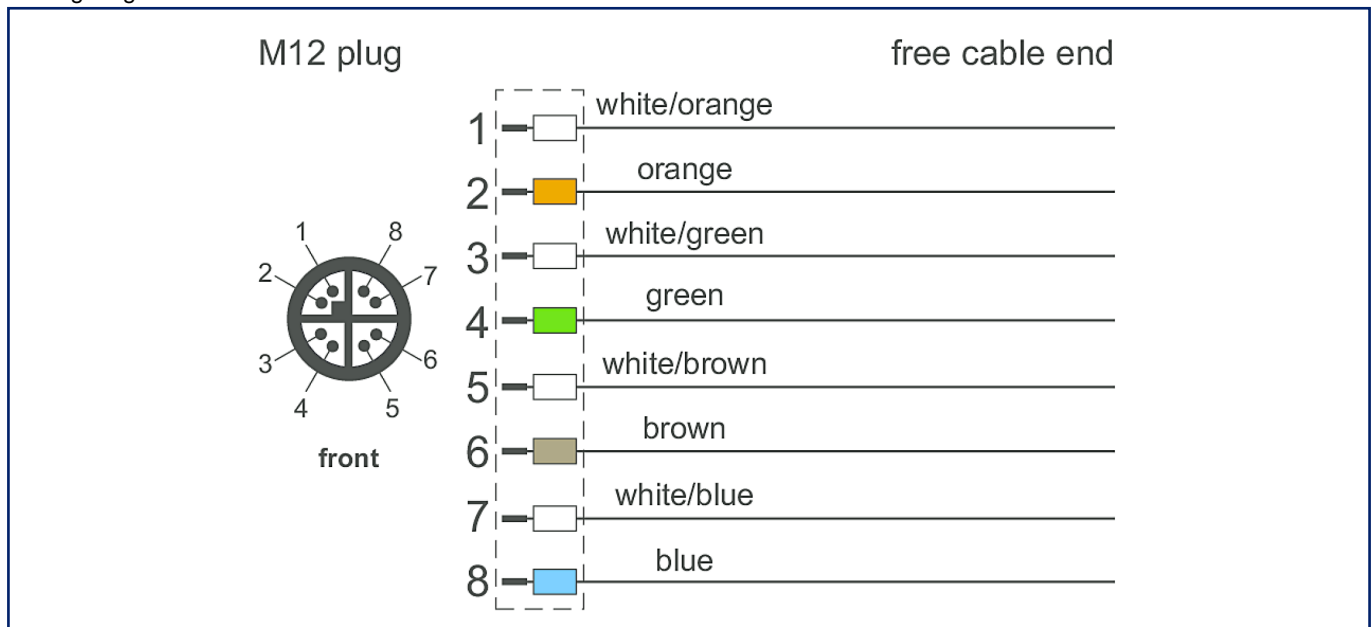

Data sheet

Page 7/7

**M12 Industrial Ethernet cable, X-coded, 2.0 m,  
M12 plug straight - free line end, torsion, PUR**

P/N

142M7X10020

EAN 4250184199281

2025/05/19

Version: L

## Illustrations

Principle diagram

